

SureDrop Collar Break-Off Mechanism

User Manual

Version 1.2

Feb, 2023

Manufacturer: Advanced Telemetry Systems, Inc.
470 First Avenue North
Isanti, MN 55040
763-444-9267
www.atstrack.com

1.0 SD30u SureDrop Communication Software Overview

This describes the ATS SureDrop software which is used to communicate with Advanced Telemetry Systems, Inc.'s SureDrop Collar Break-Off mechanism.

Before You Begin:

The collars you have been shipped have been preprogrammed with a default Break-Off date. It is **24 months** out into the future or a custom date supplied per your order. This date is written on the magnet shipped with each mechanism.

Limit the amount of time connected to the PC with the black WS100 Wildlink box since this is a high current mode. The amount of time in this mode will have a strong impact on the life of this mechanism.

1.1 Installation:

You must install the “ATS SureDrop” software from Advanced Telemetry Systems, Inc. onto your hard drive in order to run the program.

To start the installation, run the setup.exe program downloaded from www.atstrack.com.

The icon used to open the SureDrop software will be automatically placed on your desktop.

1.2 Operation:

The SureDrop Collar Break-Off Mechanism communicates using your PC and the **black** WS100 Wildlink box to communicate via radio wirelessly to your SureDrop mechanism. The mechanism contains a low power onboard clock that runs continuously.

There are three modes of operation...

1: Sleep mode – The mechanism is in sleep mode while the magnet is taped or in close proximity to the magnetic reed switch inside the SureDrop. This is the unit's lowest power mode. In this mode only the on-board clock is operating.

2: Countdown mode – The mechanism is in this mode when the magnet has been removed from the SureDrop. Once the magnet is removed, the countdown timer begins running until it reaches the pre-programmed number of days until the break off event is scheduled, which should lead to the collar falling off of the animal. The power use in this mode is similar to the sleep mode.

3: PC Communication via radio - In this mode, the SureDrop Collar Break-off mechanism is communicating with the “ATS SureDrop” software. This mode is entered by turning on the SureDrop Collar Break-off mechanism by removing the magnet, and opening the Communication Software. This is a high power mode so its use should be limited. You may now program your SureDrop mechanism. Programming is done in the “Archive SureDrop Configuration” screen. Once the release date is set make sure to click on the “Update Device Configuration and Clock”

button located at the bottom of the screen to make sure the new time is sent over to the *SureDrop* mechanism.

The *SureDrop* will remain in communication mode as long as the **black** WS100 Wildlink box is within range of the mechanism.

1.3 System Requirements:

- Microsoft® Windows® 7 or Microsoft® Windows® 8 or Microsoft® Windows® 10 or Microsoft® Windows® 11
- ATS **black** WS100 Wildlink box

1.4 LED Flash Definitions:

ATS Black WS100 Wildlink Box

- Flashing Red LED – Transmitting/receiving packets.
- Solid Yellow LED – Another mechanism is within range
- Solid Yellow and Green LED – Data packets are being transferred back and forth between the *SureDrop* mechanism and the PC.

SureDrop Mechanism

- Slow Flashing Yellow LED – In **Transmit Mode**
- Quick Flashing Yellow and Green LED – Connected to the PC via the ATS WS100 radio link dongle.
- Red and Green LED On – In **Test Mode**.
- Flashing Green LED and Solid Red LED – Testing boost circuit.
- Flashing Red LED and Solid Green LED – Testing firing transistor.
- 5 Green LED Flashes – **Run Mode** starting.
- 1 Red LED flash per minute – Firing circuit has failed its test and it is in run mode
- 1 Green LED flash per minute – Firing circuit has passed its test and it is in run mode.
- 1 Red LED flash every 10 seconds – Mechanism has fired.

Note: To switch modes use a magnet on the reed switch. Make sure to hold magnet in place 5 seconds to guarantee mode change.

2.0 ATS SureDrop Collar Break-Off Mechanism Software

2.1 Establish Wireless Connection

Before starting your *SureDrop* software attach your ATS Black WS100 Wildlink Box to your PC via a USB port.

The first screen that appears when the software is run is shown below:

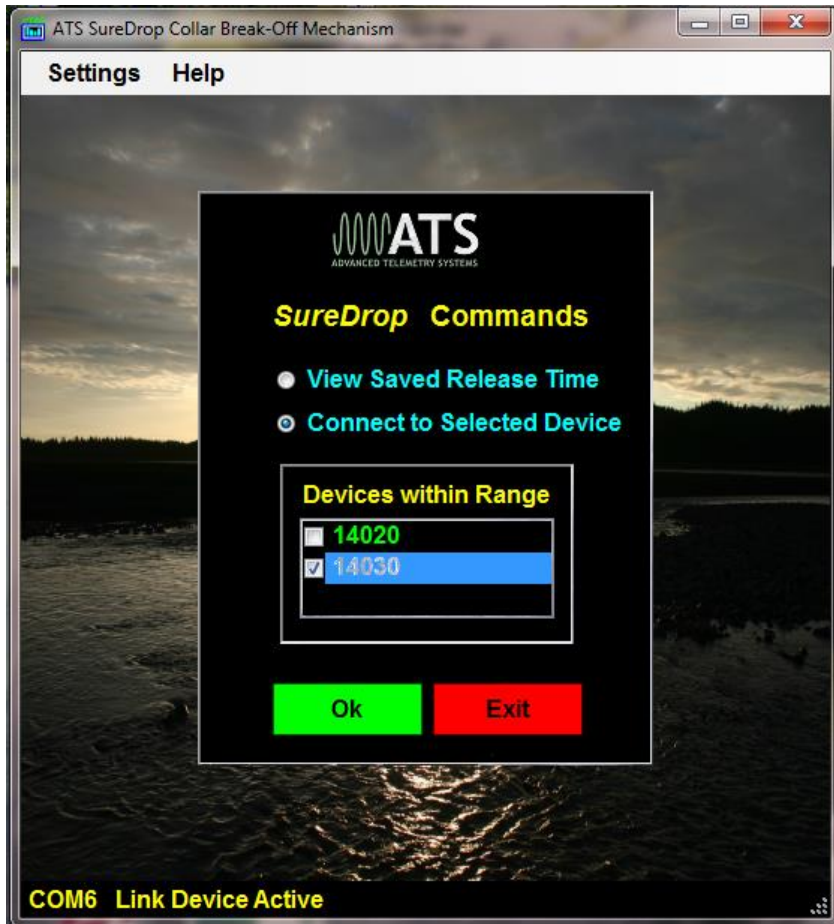

When using the software on the PC for the first time a correct “Com Port” will need to be chosen so the software can communicate with the ATS WS100 Radio Link Dongle. To select the ‘Com Port’, highlight “Settings” in the toolbar and select “Com Port” from the drop down menu. This will open a dialog box listing the available com ports. Pick your com port and exit.

Once you have this screen open with the “Link Device Active” appearing at the bottom of your screen you can proceed to the next step.

To start the wireless communication with your *SureDrop* device remove the magnet so that it can enter the PC communication mode.

When the software detects the presence of the *SureDrop* device it will appear in the Window showing all the *SureDrop* devices in range. Click on the checkbox to select the device you are working with and turn the others off.

2.2 Viewing/Editing Your Release Time

To view/edit your device’s release time select “Connect to Selected Device” and Click on the “Ok” button. If you are connected to your device you will get the following window:

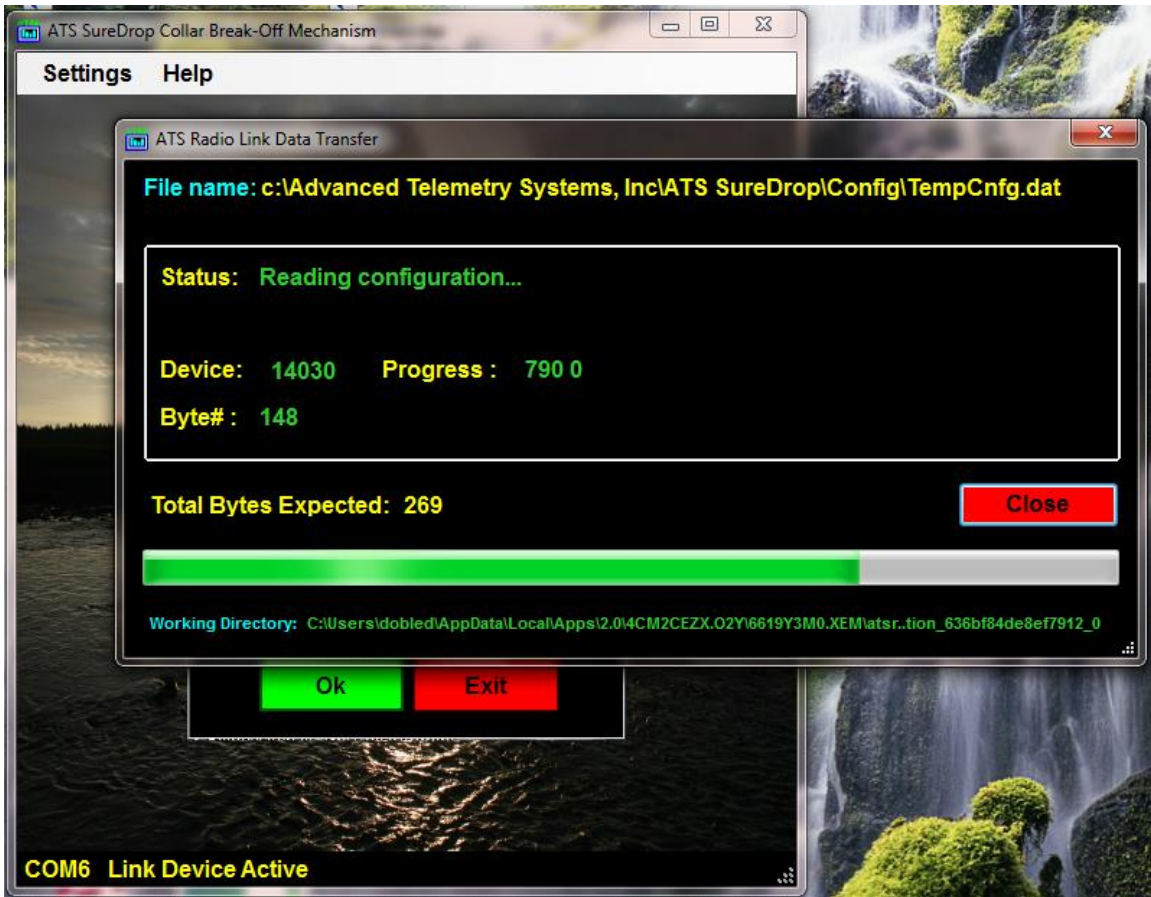

The configuration window that appears from either reading a connected tag or reading from a saved file will look something like the screen shown below:

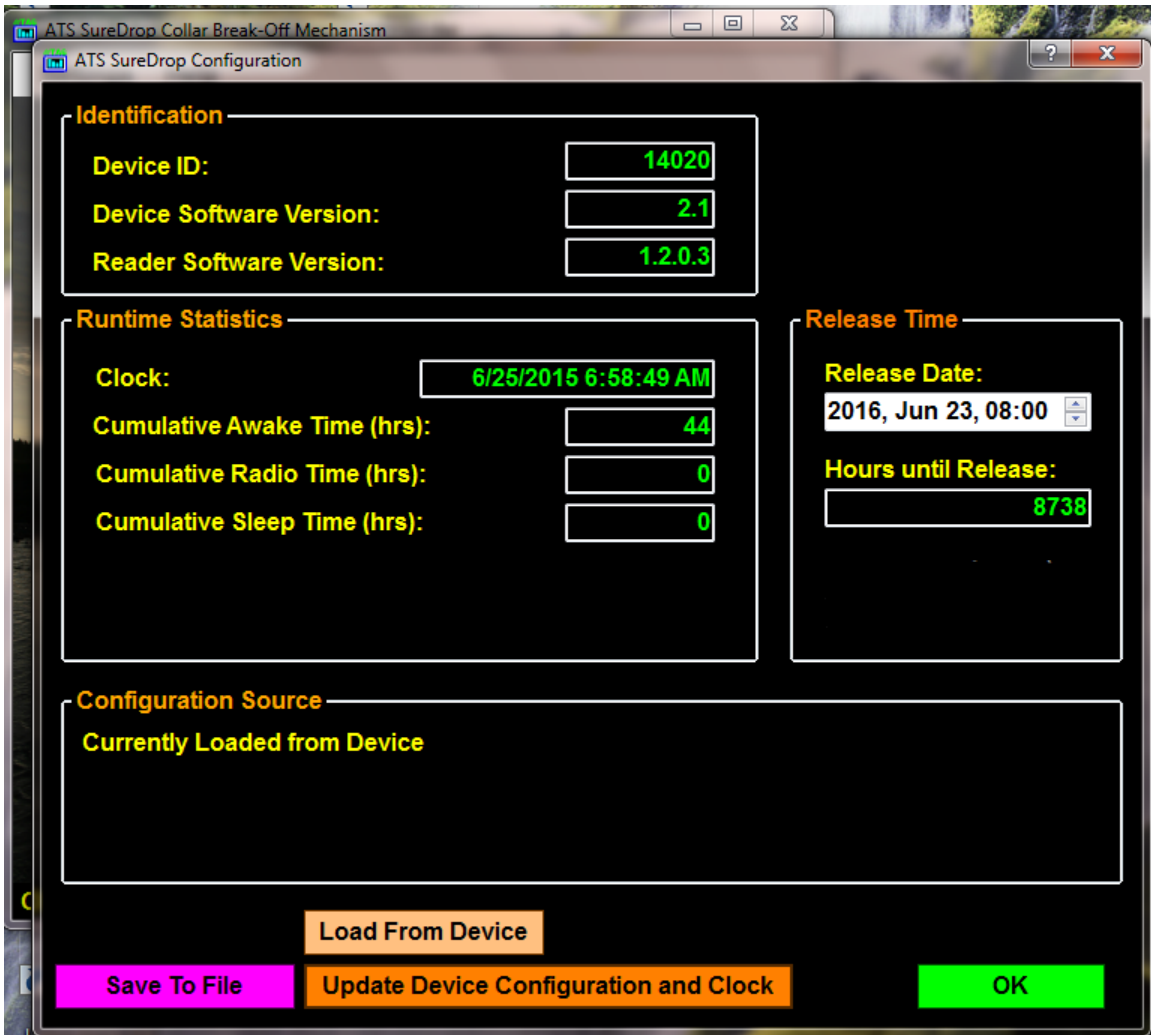

To program your SureDrop device select your "Release Date" and Click on the "Update Device Configuration and Clock" button.

3.0 SD30u SureDrop Break-Off Mechanism Drawing

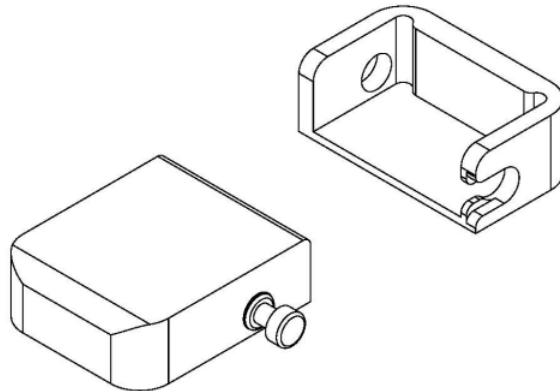

UNLOCKED POSITION

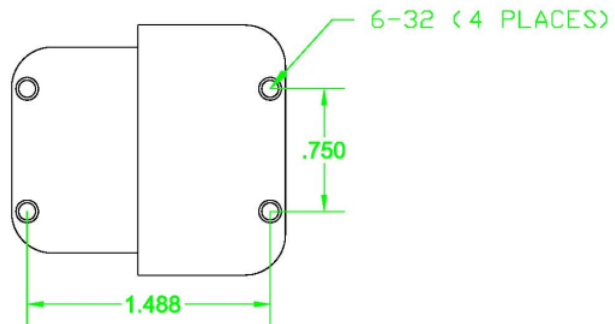
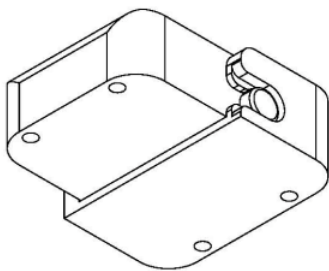

LOCKED POSITION

-
- The SureDrop is shipped with some hardware; four (4) each ½ inch 6-32 screws and washers that can be used to attach the mechanism to a collar. Use the screws hole pattern shown above.
 - Make sure to use a thread locker to make sure the screws do not back out.
 - When the programmed release time is reached the metal holding pin will pop out, causing the SureDrop Collar Break-Off Mechanism to go from the locked position to the unlocked position. In order to function correctly, no material should span the two halves of the SureDrop shown that potentially cause it to catch or otherwise hold it together.

Support:

Complete product support is available from ATS' Sales and Service department.

Advanced Telemetry Systems, Inc.
470 First Ave. North

Isanti, MN 55040
Phone:763-444-9267
Fax:763-444-9384
Web: <http://www.atstrack.com/>
Email: <http://contact@.atstrack.com/>